

GLASS PASSIVATED FAST RECOVERY BRIDGE RECTIFIERS

Features

- ◆ Ideal for printed circuit board
- ◆ Reliable low cost construction utilizing molded plastic technique
- ◆ High temperature soldering guaranteed: 260°/10 seconds at 5 lbs., (2.3kg) tension
- ◆ Small size, simple installation
- ◆ High surge current capability
- ◆ Glass passivated chip junction
- ◆ Leads solderable per MIL-STD-202, Method 208

Mechanical Data

Case : JEDEC ABS Molded plastic body

Terminals : Solder plated, solderable per MIL-STD-750, Method 2026

Polarity : Polarity symbol marking on body

Mounting Position : Any

Weight : 0.003 ounce, 0.098 grams

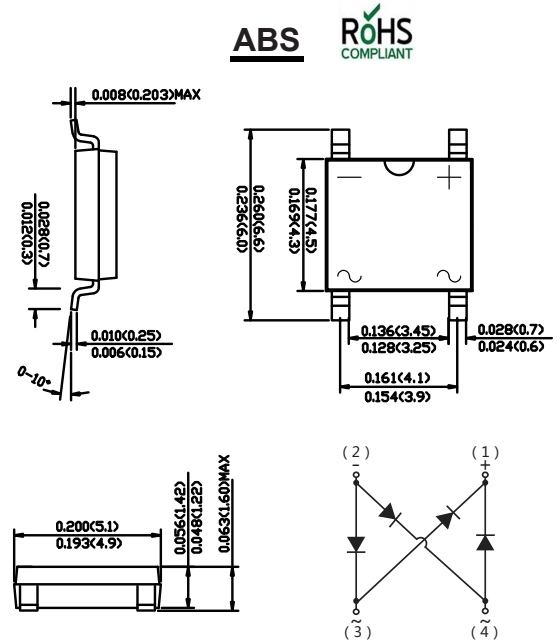

Dimensions in inches and (millimeters)

Maximum Ratings And Electrical Characteristics

Ratings at 25°C ambient temperature unless otherwise specified.

Single phase half-wave 60Hz, resistive or inductive load, for capacitive load current derate by 20%.

Parameter	SYMBOLS	MDD RABS2	MDD RABS4	MDD RABS6	MDD RABS8	MDD RABS10	UNITS
Marking Code							
Maximum repetitive peak reverse voltage	V_{RRM}	200	400	600	800	1000	V
Maximum RMS voltage	V_{RMS}	140	280	420	560	700	V
Maximum DC blocking voltage	V_{DC}	200	400	600	800	1000	V
Maximum average forward rectified current On glass-epoxy P.C.B.(Note1) On aluminum substrate(Note2)	$I_{F(AV)}$			0.8 1.0			A
Peak forward surge current, 8.3ms single half sine-wave superimposed on rated load (JEDEC Method)	I_{FSM}			30			A
Maximum instantaneous forward voltage drop per leg at 0.4A	V_F			1.3			V
Maximum DC reverse current at rated DC blocking voltage $T_A=25^\circ C$ $T_A=100^\circ C$	I_R			5 500			μA μA
Typical thermal resistance(NOTE 3)	$R_{\theta JL}$			25			$^\circ C/W$
	$R_{\theta JA}$			75			
Maximum reverse recovery time (NOTE 4)	t_{rr}			500			ns
Operating temperature range	T_J			-55 to +150			$^\circ C$
storage temperature range	T_{STG}			-55 to +150			$^\circ C$

NOTES:1. On glass epoxy P.C.B. mounted on 0.05x0.05"(1.3x1.3mm) pads.

2. On aluminum substrate P.C.B. with an area of 0.8"x0.8"(20x20mm) mounted on 0.05X0.05"(1.3X1.3mm) solder pad.

3. Thermal resistance from junction to ambient and junction to lead mounted on P.C.B. with 0.2X0.2"(5X5mm) copper pads.

4. Reverse recovery condition $I_F=0.5A, I_R=1.0A, I_{rr}=0.25A$.

Ratings And Characteristic Curves

FIG.1 FORWARD DERATING CURVE

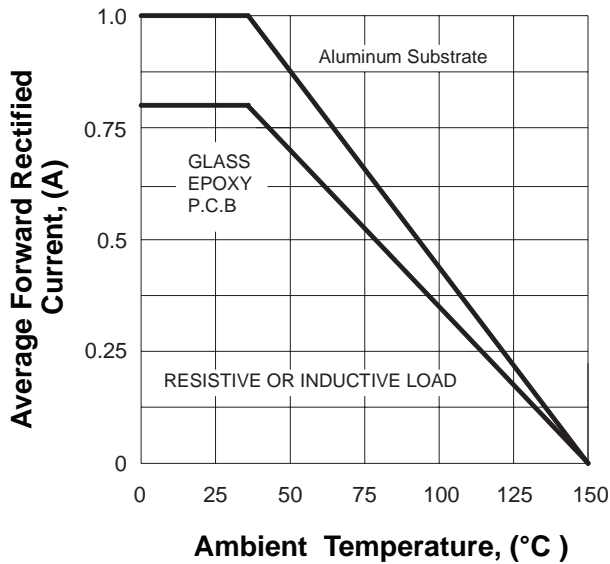

FIG.2 PEAK FORWARD SURGE CURRENT

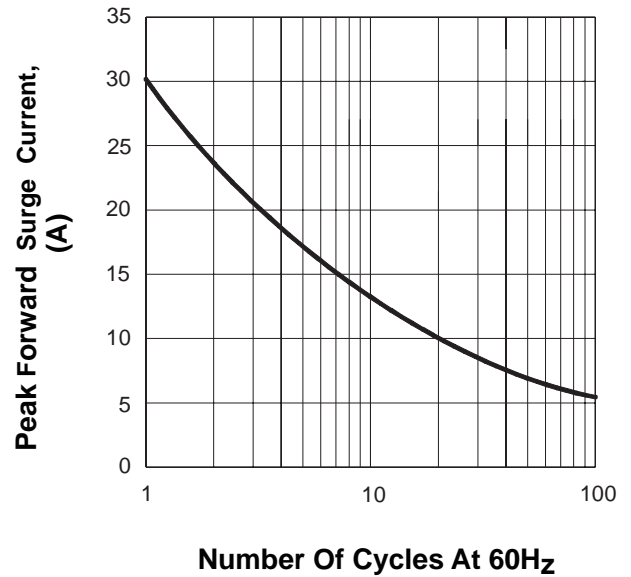

FIG.3 TYPICAL FORWARD CHARACTERISTICS

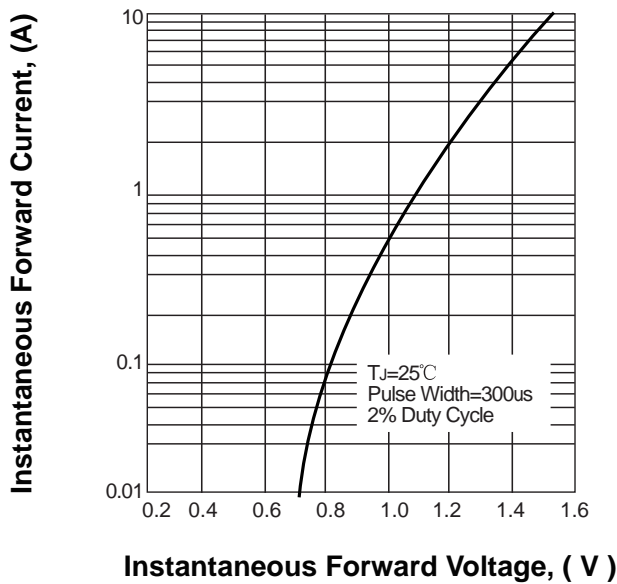
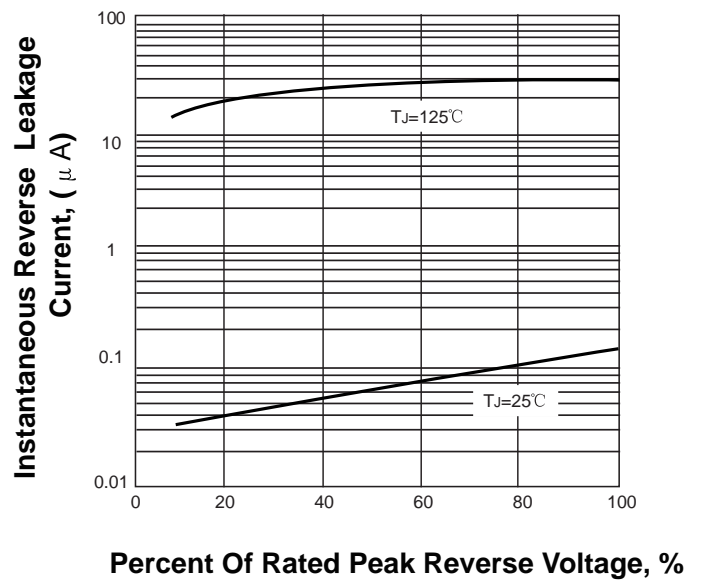
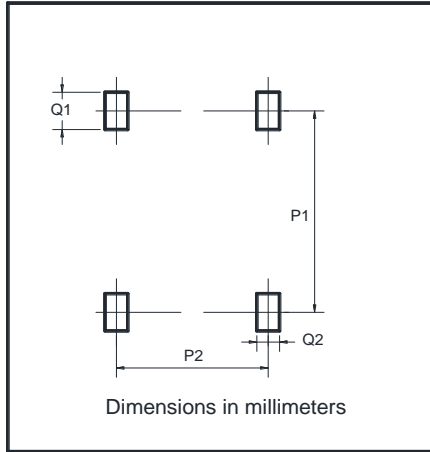

FIG.4 TYPICAL REVERSE CHARACTERISTICS



The curve above is for reference only.

Suggested Pad Layout



Dim	Min
P1	5.72
P2	4.00
Q1	1.00
Q2	0.90